

Part #440-6 R/B Valley Cover Plate

Use with either wedge or Hemi engine. Part #400-6 available for B engines. Both numbers can be used with 440-SR items if manifold has clearance.

Part #440-6R R/B Valley Cover Plate

Needed to facilitate cam changing or at track lifter inspection. Does not require head removal to access the lifter valley. Part #400-6R available for B engines.



Part #440-7 Valve Covers

Light weight tall aluminum cast logo valve covers. Fits all Indy Wedge heads and can be used on all stock heads. Part #440-8 no logo plain.



Part #440-24 Reverse Flow Plate

Converts the big block Chrysler to reverse flow, now the cool water enters the heads first. Can be used to mount your engine block using your motor plate. (15 HP gain).



Part #440-24 with Meziere Water Pump

You can purchase everything you need to put the 440-24 plate on your engine. Shown here with Meziere billet pump and fittings. (Must fabricate top radiator hose).



Part # Pre-D3-100 and 102

Single or double head offset distributor with a big 5" cap. They are available for B, RB and small block engines. This piece is a must for any Predator engine or small block blower motor using a Mod Man intake. It's also a great solution for anyone needing extra clearance. The double head distributor is the final piece you need for your 16 plug Hemi.



Part # 440-22 Timing Cover

Cast aluminum timing chain cover. B or R/B block uses stock shaft seal. Will not flex under cam button pressure. With O.E.M. water pump you must use elephant ears or 1/4" water pump spacers Indy #440-22S.



Part #440-22S

Water pump spacers that must be used when a #440-22 is used in combination with an O.E.M. style water pump.

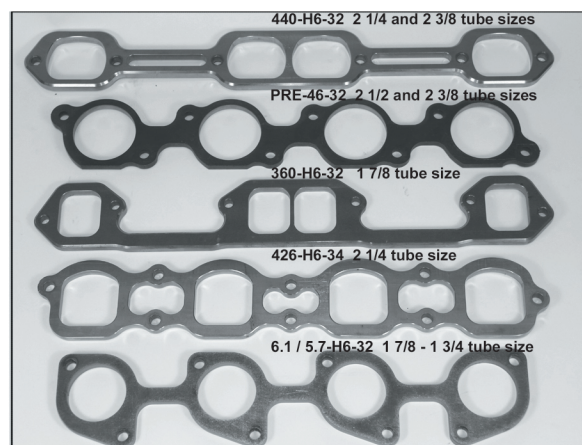

Header Flanges

The hardest part about custom headers is finding flanges that fit your exhaust port. These steel header. Flanges (440-32 Wedge and 426-34 Legend) are CNC cut to fit your Indy heads.